



Technical Documentation

Radial Pump with Canned Motor

MY3-MM

Technical Documentation

Radial Pump with Canned Motor

MY3-MM

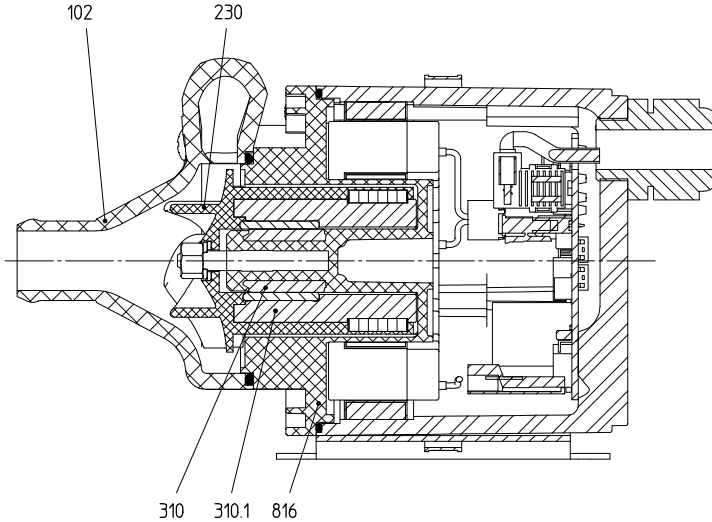

Description

Hermetically sealed small centrifugal pump with canned motor.

Impeller (230) and inner magnet form a unit, that is supported by a medium-lubricated sleeve bearing (310). The power transmission from motor to shaft is produced by a rotating field, generated by coils, directly to the inner magnet.

The can (816) separates the pumping chamber from the atmosphere. An integrated electronic circuit provides for the rotating field and controls the pump speed.

The drive is free from bearings and rotating components: No maintenance is necessary in standard operation.

Applications

The pump can be used in the following fields of application, e.g.:

Temperature controlling and industrial cooling

- delivery of cold brine
- maintenance of cooling circuits
- air-conditioning of the passenger compartment in trucks, buses, trains and vehicles with fuel cell plants

Further applications

- drinking water supply in railcars
- etc.

Technical Data

Pumped media	Clear or unclear liquids or mixtures without solids and with good lubricating qualities, not aggressive to the pump components, density and viscosity similar to water. Other liquids on request.
Temperature / Medium	-30 °C up to +80 °C (-22 °F up to +176 °F), medium has to be liquid!
Installation	Dry installation in buildings or in roofed places outdoors. Not permitted in Ex-zones.
Ambience	-30 °C up to 40 °C (-22 °F up to +176 °F) ambient temperature, max. 80% air humidity. Protect the pump against ambient atmosphere or vapours with high concentrations of acids or solvents.
Static system pressure	max. 2.5 bar (max. 36.3 psi)
Motor power	max. 180 W (0.23 HP), depending on load and speed
Nominal voltage	24 V
Operating voltage	18 to 28 V
Current consumption	max. 7.5 A, depending on load and speed
Fuse	10 A
Speed	20 mm (0.8") hose connectors: 2000 up to 6500 rpm 28 mm (1.1") hose connector: 2000 up to 6000 rpm possible parameters set by Speck Pumpen
Direction of rotation	Right (view from pump front side), cf. marking on pump ...
Protection class	IP 54
Sound pressure level	max. 46 db(A) in a distance of 1 m (3.3 ft) to all sides
Connecting wire	1000 mm +/- 20 mm (39.3" +/- 0.8") PVC-protection tube with loose wire-endings 50 mm (1.9"), isolated without ferrules, 5 mm (0.2") stripped. See detailed information in table „wire specification“
Cable connection	M16 x 1.5 plastics black
Pumping capacity	20 mm (0.8") hose connectors: $H_{max.}$ 14,0 m (46 ft), $Q_{max.}$ 70 l/min (18.5 USGPM) 28 mm (1.1") hose connectors: $H_{max.}$ 12,5 m (41 ft), $Q_{max.}$ 100 l/min (26.4 USGPM)
Lifetime	20,000 hours of operation according to standard mode of operation
Protection against dry running	Not existing, the pump has to be protected against dry running by the user
Blocking protection	In the state of a blocked impeller the starting attempts will be continued indefinitely
Overload protection	Integrated electronics automatically reduce motor speed when reaching max. admissible motor temperature
Max. surface temperature	approx. +95 °C (+203 °F)
Storage temperature	-40 °C up to +120 °C (-40 °F up to +248 °F)
Lacquer	Motor casing powder-coated RAL 9005 black mat
Weight	1300 g (2.87 lbs)

Dimensions

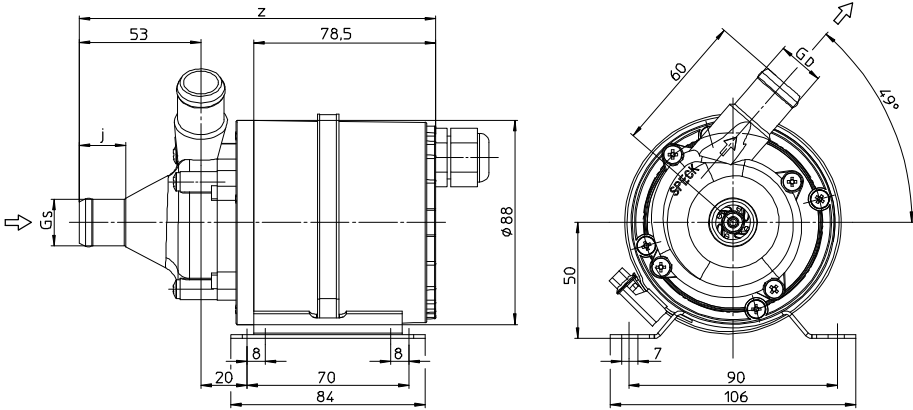

Connections

G_5 [mm]	G_6 [mm]	G_5 [inch]	G_6 [inch]	j	z
20	20	0.7	0.7	20	154
28	28	1.1	1.1	27	159

Dimensions



Material

Casing parts	PA 66 (polyamide with 30% fibre glass)
Impeller	PPS (polyphenylensulfide with 40% fibre glass)
Sleeve bearing	SiC
Separating can	PPS (polyphenylensulfide with 40% fibre glass)
O-rings	FKM

Hydraulic specifications and power consumption

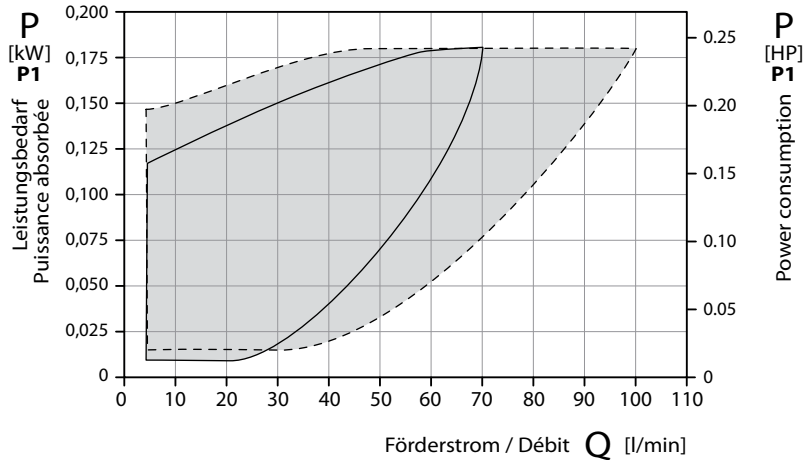
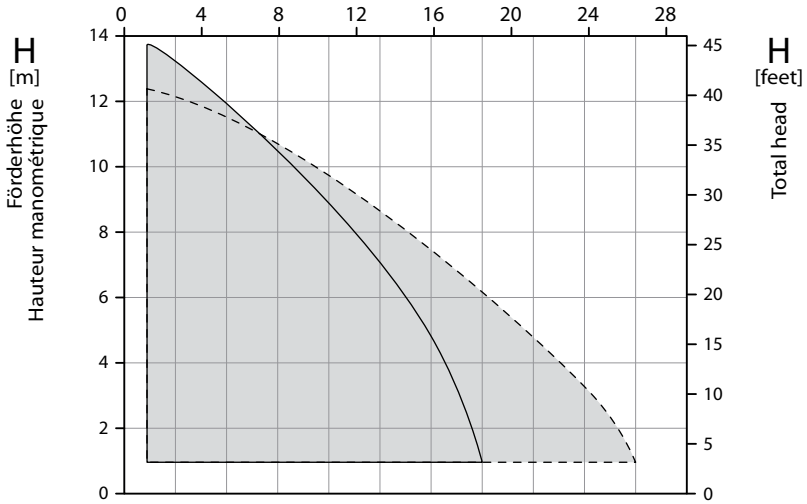
Capacity **Q** [U.S.GPM]



$G_s/G_D = 20 \text{ mm}$		2000 – 6500 l/min - rpm - tr/min
$G_s/G_D = 28 \text{ mm}$		2000 – 6000 l/min - rpm - tr/min

Every operating point can be reached within these characteristic fields by setting different drive parameters.

The characteristic fields are applicable for the delivery of water of 20 °C (68 °F) temperature and an ambient temperature of 20 °C (68 °F).

The tolerance of total head and capacity is $\pm 10\%$, performance tolerance is $+10\%$. If the property of the pumped media differs, the characteristic fields change.

The power consumption P1 specifies the electrical power input.

Fixing and installation

Pump connections

The preferred position for the installation of the pump is a horizontal position. The ideal position of the discharge hose connector is an upwards-position in a 50° angle as shown in the dimensional drawing. This position guarantees an optimized bleeding of the pump.

By loosening the tension clamp, the position of the hose connector can be relocated.

Clamping torque is 3 - 5 Nm.

Installing instructions

An open and well-ventilated place has to be chosen for the installation of the pump. Foot fastening with four M6 screws in an appropriate, accessible place. The connections of suction and delivery pipe to the pump casing and the pump connections in general should be assembled tension-free.

The size of pipings in the complete hydraulic circuit should not be less than the nominal width of the hose connectors. Do not use any kind of isolating material around the pump. Check all pipes according to fixed position and tightness.

Electrical connections

The connecting wire has to be installed tension-free.

Electrical Installation

Connect the red strand 2,5 mm² with the 24 V- positive pole of the power supply unit. Connect the black strand 2,5 mm² with the 24 V-negative pole of the power supply unit. Pay attention to use well-dimensioned cable connections.

In addition, optional features are available :

Option Adjustable speed:

Motor speed is defined by the control lines proportional to applied voltage (0 - 10 V) or current (0 - 20 mA).

Speed depends on the particular programming of the motor. If the control lines are not connected, the motor runs with a programmed speed for 0 V, respectively for 0 mA.

Connect the yellow strand 0,75 mm² with the 0 - 10 V-positive pole of the control voltage source or the grey strand with the 0 - 20 mA-positive pole of the control power source.

Connect the black strand 0,75 mm² with the negative pole of the control voltage or power source.

Option Turn on/off:

The motor can be turned on and off by the control line „Active Low“ without cutting off power supply.

Connect the green strand (Active Low) with Signal GND (black strand 0,75 mm²) to turn off the motor.

Wire specification

Supply lines

Function	Cross sections	Colour
+24 VDC	AWG 14 $\hat{=}$ 2.5 mm ²	red
Power GND	AWG 14 $\hat{=}$ 2.5 mm ²	black

Control lines

Function	Cross sections	Colour	
Signal GND	AWG 20 $\hat{=}$ 0.75 mm ²	black	option available
Active Low	AWG 20 $\hat{=}$ 0.75 mm ²	green	option available
Tach Out	AWG 20 $\hat{=}$ 0.75 mm ²	brown	option available
Control Voltage	AWG 20 $\hat{=}$ 0.75 mm ²	yellow	option available
Control Current	AWG 20 $\hat{=}$ 0.75 mm ²	grey	option available
Interface	AWG 20 $\hat{=}$ 0.75 mm ²	white	only applicable by Speck Pumpen
Interface	AWG 20 $\hat{=}$ 0.75 mm ²	blue	only applicable by Speck Pumpen

Single wires bound in a PVC-protected tube

Optional Speed signal

A speed proportional open collector square signal is issued by the brown control line (Tach Out), referring to signal GND. Speed [Hz] = frequency of rectangular signal [Hz].

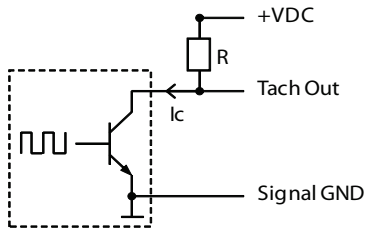

Resistance R has to be selected according to applied voltage VDC, that the current I_c may not exceed 20 mA.

At VDC = 10 V, R usually is approx. 1 k Ω .

Notice

Supply ground (Power GND) and signal ground (Signal GND) are connected internally!

Inverse-polarity protection

Supply lines (+24 VDC and Power GND) are not protected against inverse polarity, but resistant to inverse polarity for a short term. In this case the inverse polarized supply voltage is short-circuited (max. 100 A for 100 ms).

Control lines are protected up to ± 25 V (right and inverse polarized).

Initial operation

The hydraulic system has to be completely filled and bled before the first start up. The pump has to be filled with the pumped medium. For bleeding the system please pay attention to the instructions by the manufacturer.

Shut-off valves on suction side and on pressure side have to be opened completely.

The delivery of the pump medium has to be initiated immediately after commissioning the pump (no more than 5 seconds). If priming does not occur, the pump has to be turned off to avoid damages of dry running.

Trouble shooting

Disturbance	Cause	Action
Pump does not deliver	Supply suction pipe and pump are not bled correctly or not filled completely	Fill or bleed pump and/or pipes completely
	Motor does not run	Connect motor to the power supply correctly
	Hydraulic parts of the pump are blocked or stuffed by solids	Disassemble pump, remove solids
	Hydraulic parts of a pump are dirty, sticky, incrustated or worn out	Disassemble pump, clean pump parts
Pump delivers with interruptions	Supply suction pipe and pump are not bled correctly or not filled completely	Fill or bleed pump and/or lines completely.
Delivery performance too low	Electronical parts too hot: Motor reduces speed	Keep motor ventilated

UL approvals of material used

Component	Material, manufacturer, note	UL
Motor electronics	Circuit board, plug and plastic material contacting the leads	UL94 V-0
Casting compound	WEVO casting compound PD 4431 FL The electronic components are covered, only electrolyte capacitors and terminal pins stick out.	UL94 V-0 (UL / CSA-File E108835)
Motor casing	Aluminium die cast Coating powder polyester resin Interpon®	Irrelevant UL 1332
Separating can	ALBIS PLASTIC GmbH, Tedur® L 9107-1 (PPS-GF40)	UL94 V-0 (UL / CSA-File E80168)
Impeller	ALBIS PLASTIC GmbH, Tedur® L 9107-1 (PPS-GF40)	UL94 V-0 (UL / CSA-File E80168)
Volute casing	Ensinger Tecamid 66 GF 30 (PA 66 GF30) PA66 basic material Optionally: ALBIS PLASTIC GmbH, Tedur® L 9107-1 (PPS-GF40)	UL94 HB (UL / CSA-File E41938) (UL / CSA-File E47960) UL94 V-0 (UL / CSA-File E80168)
Strands	The connecting wire is executed as single strands bundled in an insulating sleeve.	UL3266 / CSA AWM I A/B
Insulating sleeve	PVC	UL-224
Wire connection	Jacob GmbH, polyamide PA6	UL 514B (UL / CSA-File E140310)